

TSS1-Hシリーズ 7.5kVA~50kVA 耐熱クラス:H種

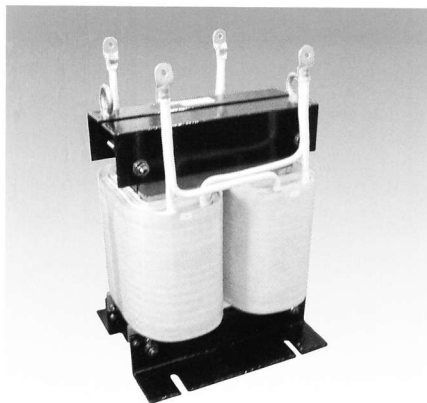

■結線図

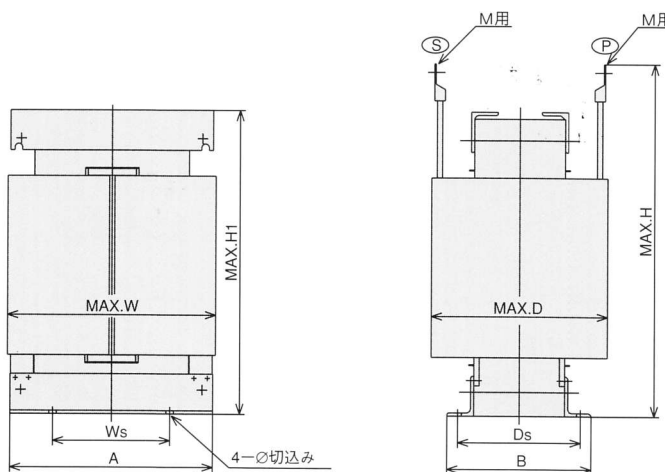
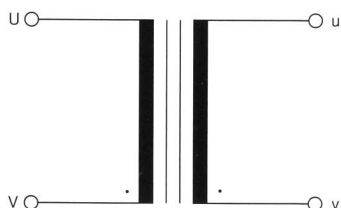

■TSS1-Hシリーズ仕様

形名	容量 (VA)	外形寸法 (mm)						取付寸法 (mm)			圧着端子			質量 (kg)
		W	D	H	H1	A	B	Ws	Ds	φ	400V	200V	100V	
TSS1-7.5KH	7.5 k	290	220	340	320	270	180	160	150	14	M6	M8	M8	55
TSS1-10KH	10 k	300	230	380	345	280	190	160	150	14	M6	M8	M10	67
TSS1-15KH	15 k	310	250	440	395	290	255	160	200	14	M8	M8	M12	87
TSS1-20KH	20 k	320	260	490	440	300	240	160	200	14	M8	M10	M12	113
TSS1-30KH	30 k	380	310	540	475	360	245	220	200	14	M8	M12	M16	150
TSS1-50KH	50 k	400	330	670	580	380	270	220	230	14	M10	M16	M20	230

SCA1シリーズ 6.3VA~1kVA 耐熱クラス:B種

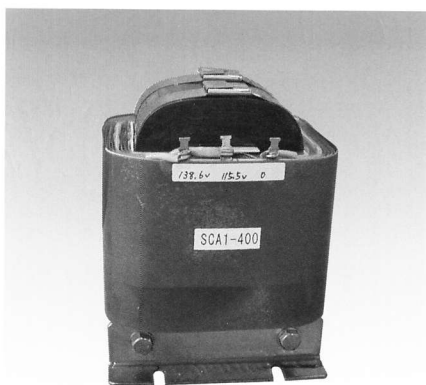

■結線図

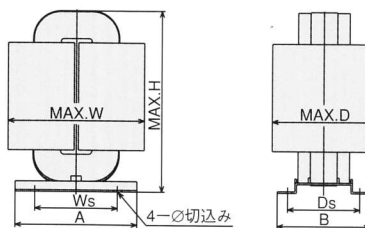
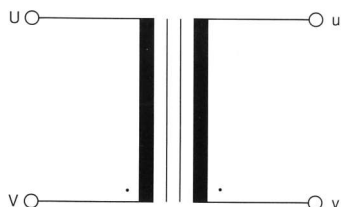

■SCA1シリーズ仕様

形名	容量 (VA)	外形寸法 (mm)						取付寸法 (mm)			質量 (kg)
		W	D	H	A	B	Ws	Ds	φ		
SCA1-6.3	6	55	40	65	47	38	30	28	4	0.25	
SCA1-8	8	60	40	65	52	40	35	30	4	0.30	
SCA1-10	10	60	40	75	52	40	35	30	4	0.35	
SCA1-16	16	60	50	75	52	45	35	35	4	0.45	
SCA1-20	20	60	55	85	52	50	35	40	4	0.6	
SCA1-25	25	66	50	95	59	45	40	35	4	0.7	
SCA1-32	32	66	55	95	59	50	40	40	4	0.8	
SCA1-40	40	66	60	95	59	60	40	45	4	1.0	
SCA1-50	50	85	55	115	74	45	50	35	5	1.3	
SCA1-63	63	85	60	115	74	55	50	45	5	1.5	
SCA1-80	80	85	70	115	74	66	50	53	5	1.8	
SCA1-100	100	85	75	115	74	70	50	60	5	2.1	
SCA1-125	125	105	70	135	90	62	60	50	5	2.4	
SCA1-160	160	105	80	135	90	70	60	60	5	2.7	
SCA1-200	200	105	90	135	80	90	45	72	4.5	3.4	
SCA1-250	250	105	100	145	80	100	45	82	4.5	3.9	
SCA1-320	320	130	100	145	110	90	60	72	5.5	4.5	
SCA1-400	400	130	115	145	110	105	60	87	5.5	5.5	
SCA1-500	500	145	110	150	110	95	60	71	5.5	6.0	
SCA1-630	630	145	130	150	110	110	60	86	5.5	7.0	
SCA1-800	800	145	145	150	130	145	75	110	5.5	8.5	
SCA1-1000	1000	160	150	185	130	145	75	110	5.5	11.5	